



Funded by
the European Union



Schweizerische Eidgenossenschaft
Confédération suisse
Confederazione Svizzera
Confederaziun svizra

Swiss Confederation

Federal Department of Economic Affairs,
Education and Research EAER
**State Secretariat for Education,
Research and Innovation SERI**
EU Framework Programmes

H O R I Z O N E U R O P E

H E A T W I S E

www.heatwise.eu

Maj 2026





Funded by
the European Union



Schweizerische Eidgenossenschaft
Confédération suisse
Confederazione Svizzera
Confederaziun svizra

Swiss Confederation

Federal Department of Economic Affairs,
Education and Research EAER
**State Secretariat for Education,
Research and Innovation SERI**
EU Framework Programmes

Anvendelse af lokal overskudsvarme i bygningssystemer.

Måling, potentiale, og design.

Af Simon Pommerencke Melgaard

www.heatwise.eu

Maj 2026



Hvorfor skal vi genbruge overskudsvarme lokalt?

- Danmarks klimakorrigerede endelige energiforbrug i 2023: **164 TWh^a**
- Opvarmning af handel og service bygninger udgjorde 7,7%^a tilsvarende **12,6 TWh**
- Arealet af alle handel og service bygninger var 97,1 mio. m² fordelt på **160.000 bygninger^b**
- Handel og service bygninger har i gennemsnit
 - et opvarmningsbehov på **123 kWh/m² per år**
 - et areal på **607 m²**

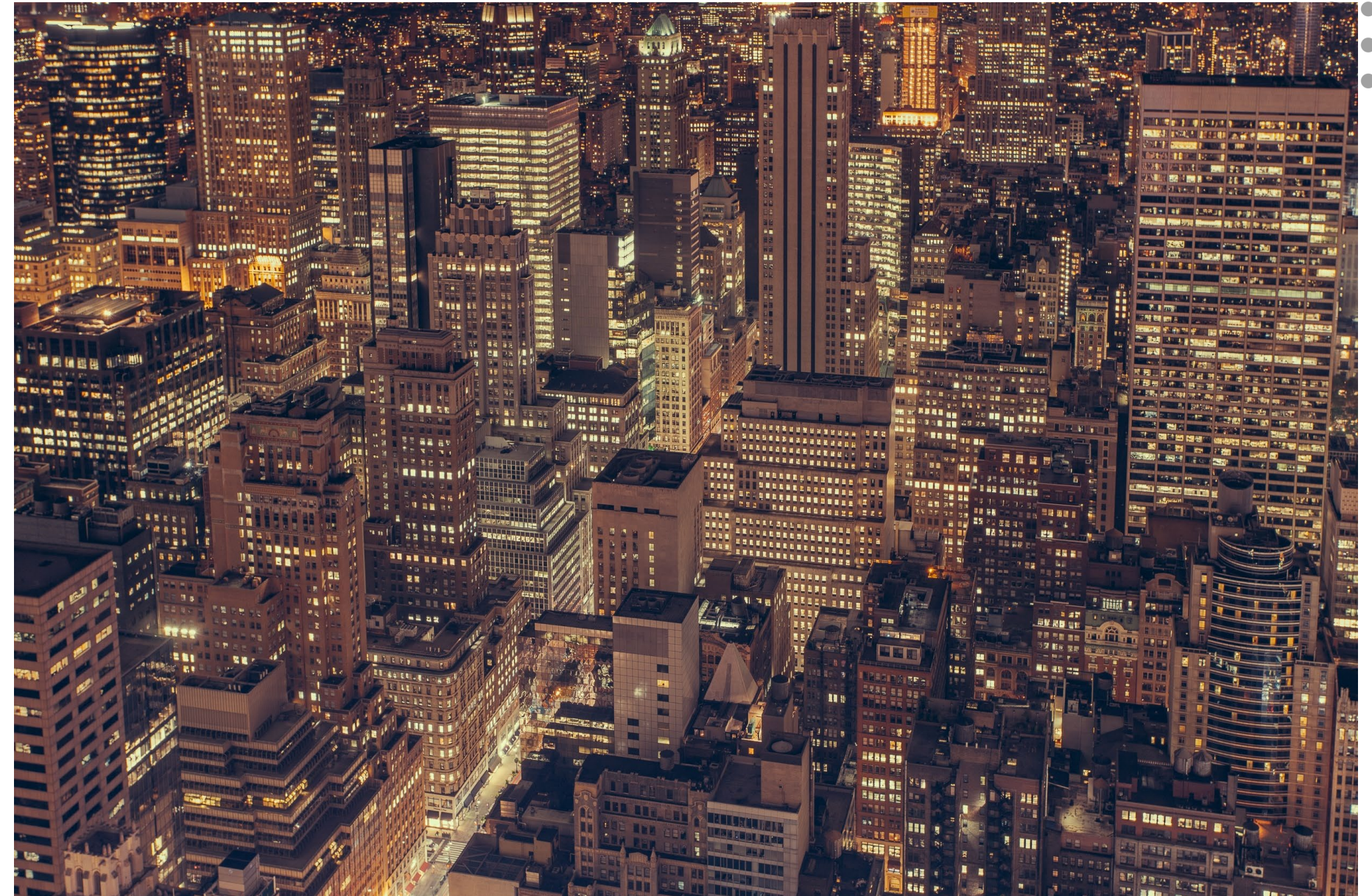

^a <https://ens.dk/media/6788/download>

^b <https://www.statistikbanken.dk/bygb50>

Hvorfor skal vi genbruge overskudsvarme lokalt?

- Server rum i kontorbygninger har typisk **1-10 server kabinetter**
 - Hvert kabinet vil forventeligt have en mærkeeffekt på 2-10 kW^a, og vil antagelsesvis producere 5840 – 29200 kWh^b
 - 1 server rum kan derved teoretisk dække opvarmningsbehovet for 48 - 2400 m² gulvareal
 - Den gennemsnitlige bygning kan på årsbasis dækkes af **25 kW servereffekt** svarende til **2-3 fulde server kabinetter**^c



^a <https://www.datacenters.com/news/kw-per-rack-explained-optimize-your-data-center>

^b Antaget at de bruger 50% af deres mærkeeffekt i gennemsnit, samt at varmesæsonen dækker 8 måneder af året.

^c Tager ikke højde for spids belastninger og ujævn belastning

Hvordan vurderes potentialet for at genbruge overskudsvarme lokalt i eksisterende bygninger?

- Der skal måles 2 parametre per system
 - Fremløbs temperatur behov
 - Energi forbrug
- Der skal tages højde for
 - Sæsonmæssig variation
 - Daglig variation
 - Er systemet fleksibelt?
 - Ventilation – delvist
 - Opvarmning – Ja
 - Varmt brugsvand – Nej (ved veksler), Ja (ved tank)

Eksempel fra ventilationsanlæg

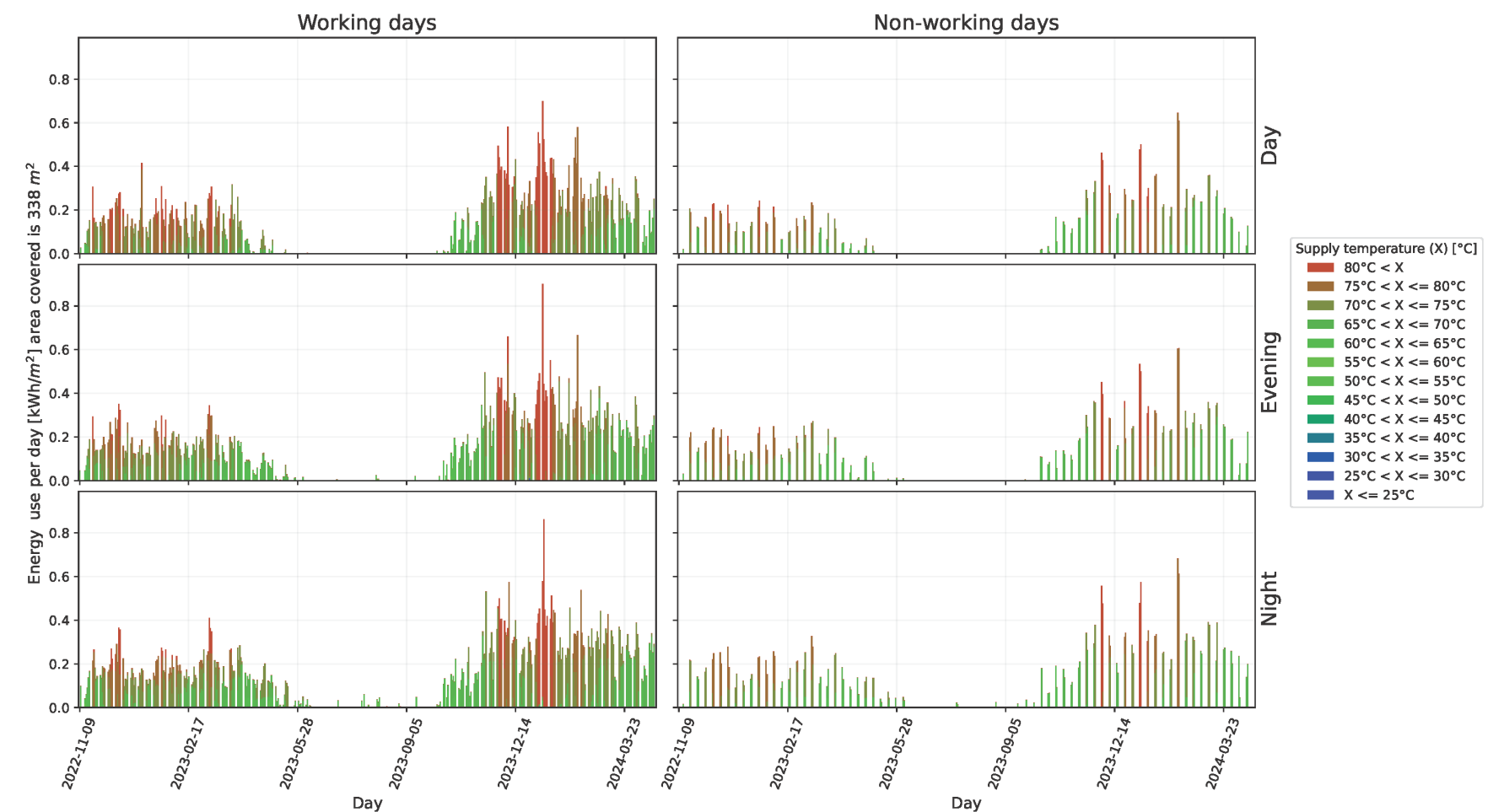

Hvad er temperatur behovet?

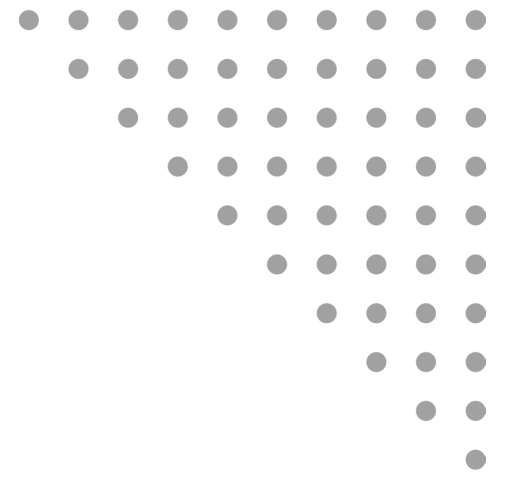

- Hvor skal vi måle henne?
 - T3 (på hovedmåleren) – Nej
 - T2 (på bimåleren før sidste blandesløjfe) – Nej
 - T1 (fremløbstempersensor efter sidste blandesløjfe) – Ja
 - Brug dimensionerende temperatur? - Nej

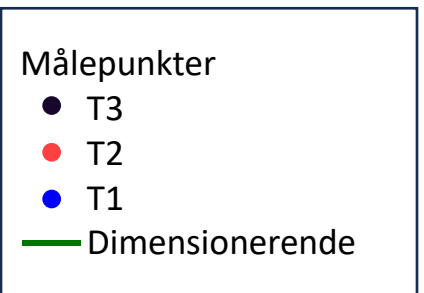
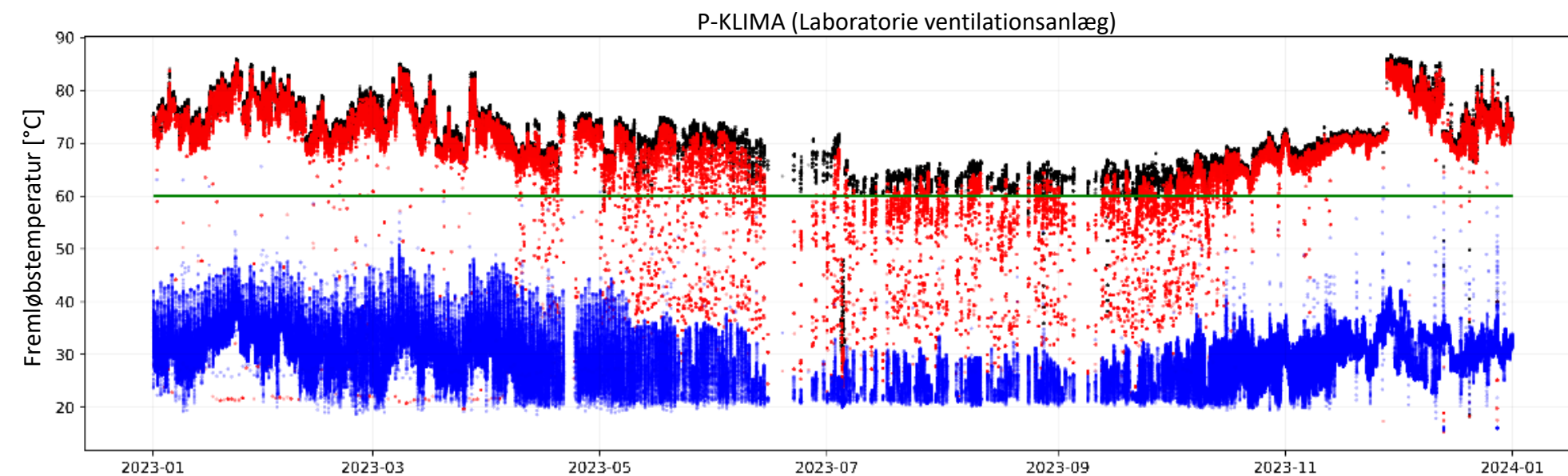
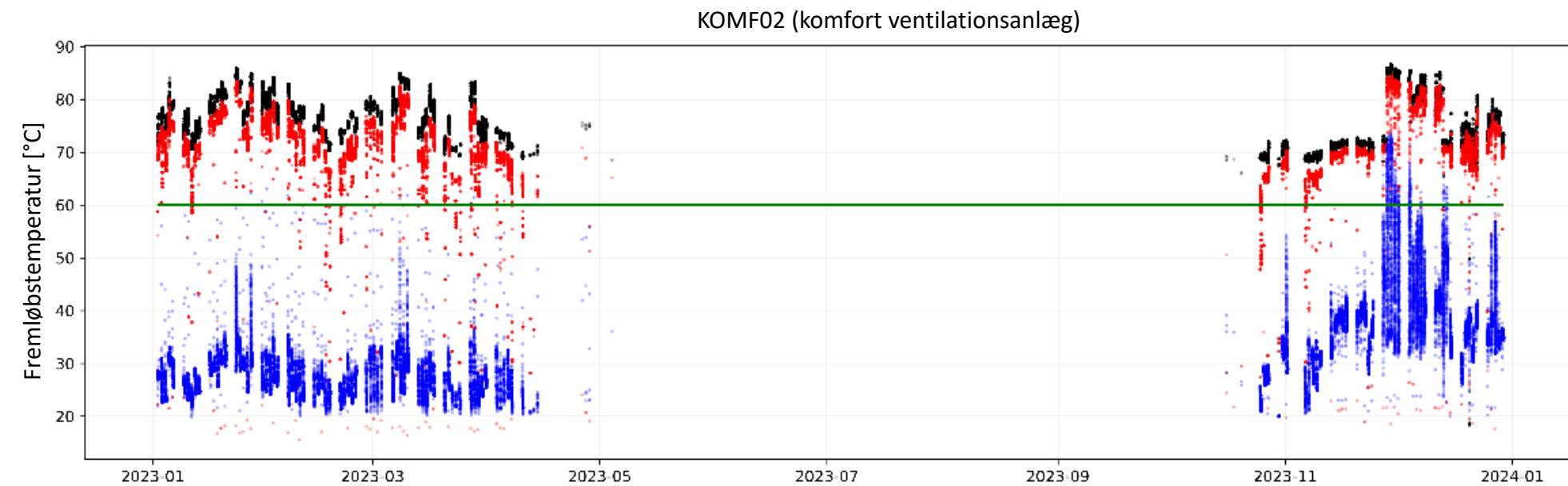
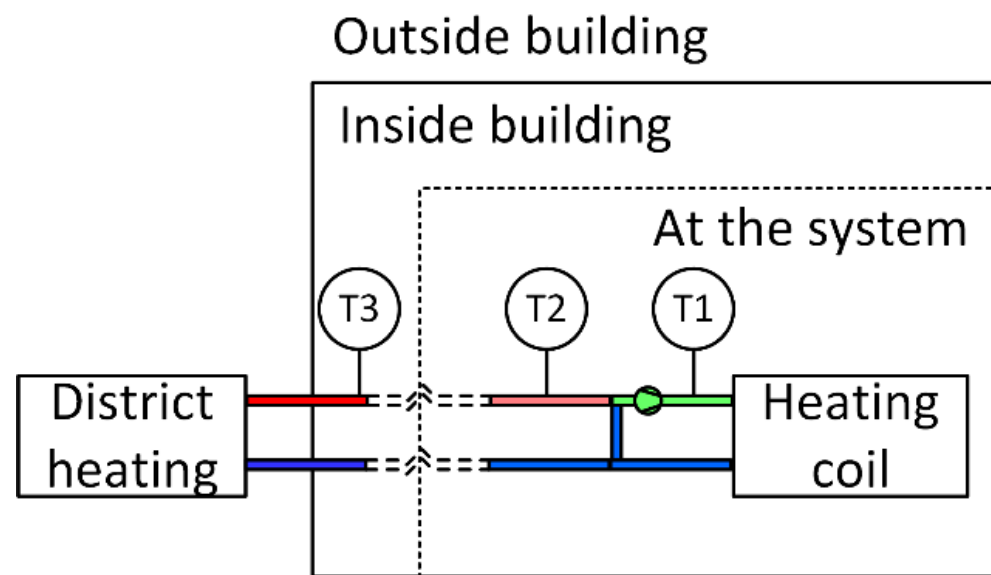

Hvad er energi forbruget?

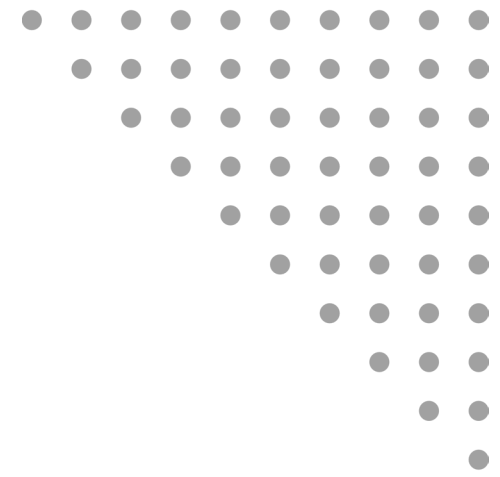

- Hvor meget af det årlige forbrug kan teoretisk dækkes ved forskellige temperaturer?

Fremløbs temperatur (T1)	Rum opvarmning [kWh/m ² per år]	Ventilation [kWh/m ² per år]	Varmt brugsvand [kWh/m ² per år]	Totalt energi besparelses potentiale*
30°C	1,4	5,7	0	15%
40°C	1,8	18,1	0	38%
50°C	3,3	19,2	0,8	51%
60°C	11,2	19,3	1,8	72%
70°C	14,0	19,3	1,8	79%

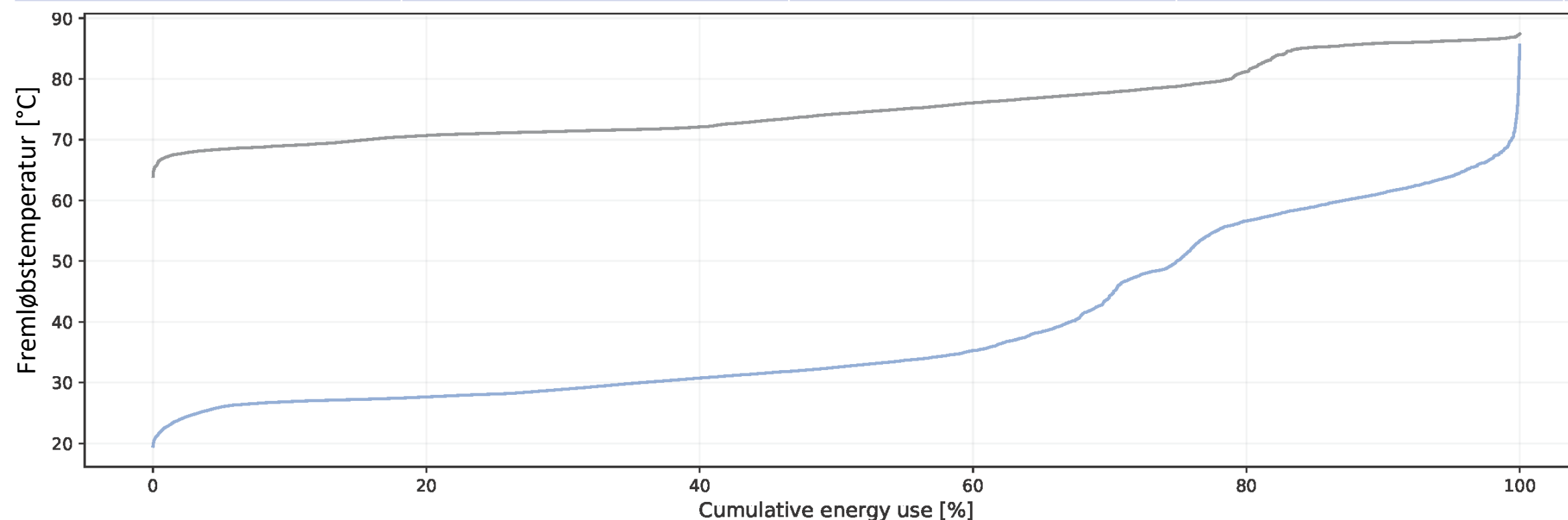

— Fjernvarme hovedforsyning (T3)
— Alle systemer med T1 temperatur måling
(Se tilhørende rapport for overblik over inkluderede systemer)

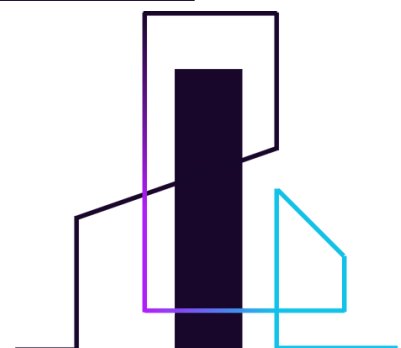

HEATWISE

Hvilke temperaturer kan leveres fra serverrum?

- Hvilke temperaturer kan overskudsvarmen fra et serverrum leveres ved?
 - Luft kølet → vand temperatur < 20°C^a
 - Luft til væske kølet → vand temperatur < 30°C^a
 - Væske kølet → vand temperatur < 60°C^a
 - Dette scenarie er afhængigt af anvendelses typen
 - 2-fase væske kølet → vand temperatur < 70°C^b
 - Dette scenarie er afhængigt af anvendelses typen

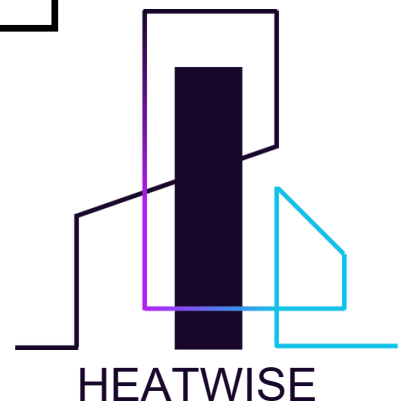
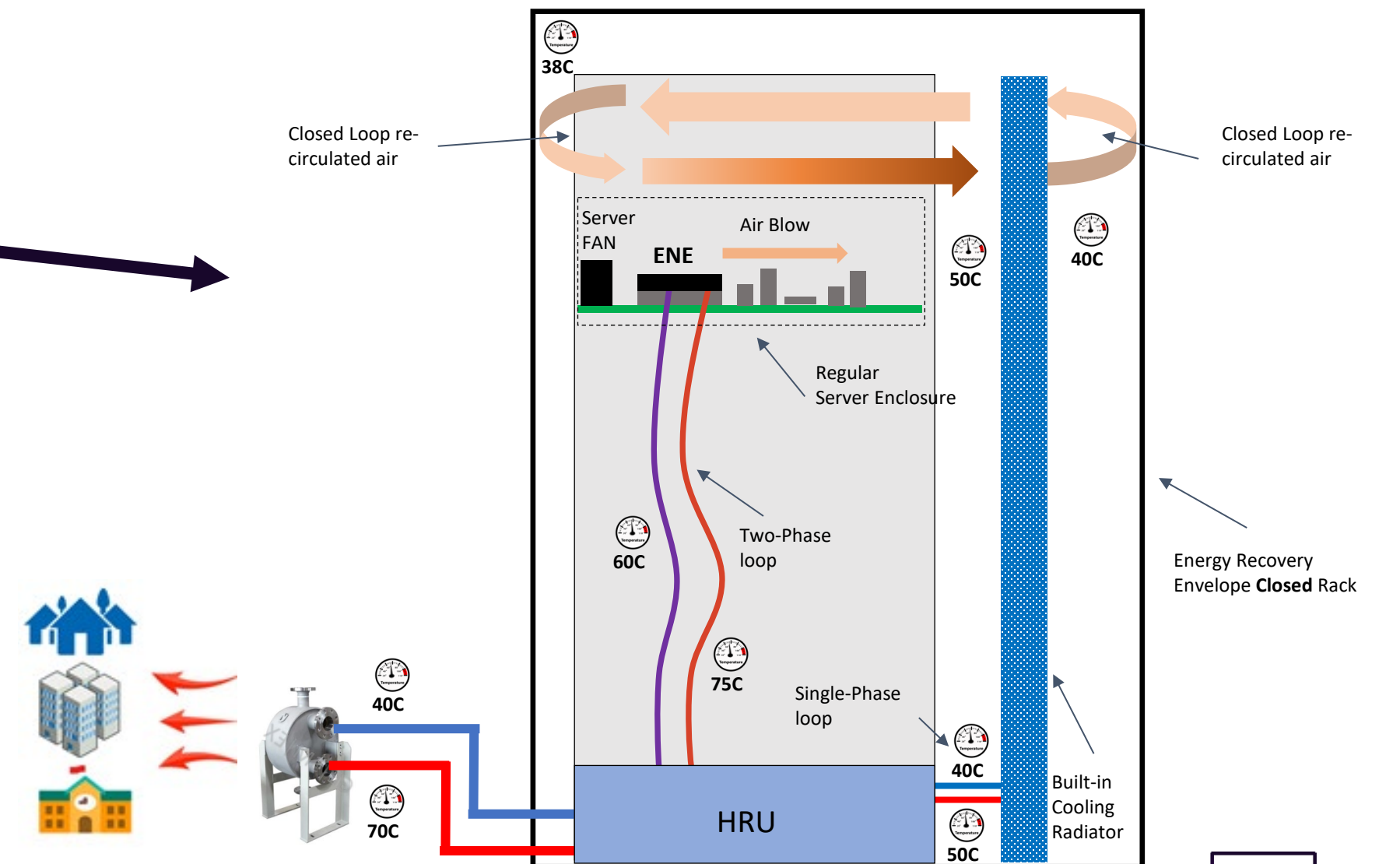

^a Yuan, X., Liang, Y., Hu, X., Xu, Y., Chen, Y., Kosonen, R. (2023). Waste heat recoveries in data centers: A review. Renewable and Sustainable Energy Reviews, 188, 113777. <https://doi.org/10.1016/j.rser.2023.113777> (Table 1)

^b ZutaCore

Hvor fleksible kan systemerne være?

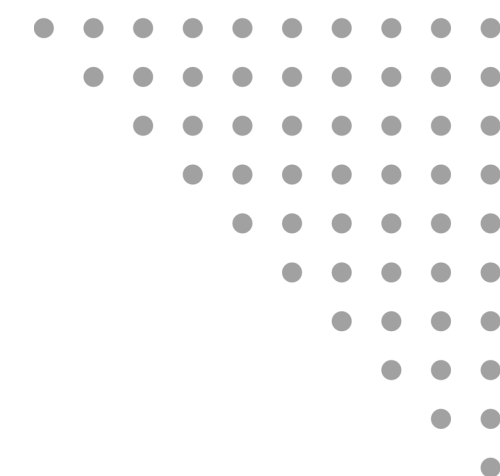

- Eksempel fra ventilation

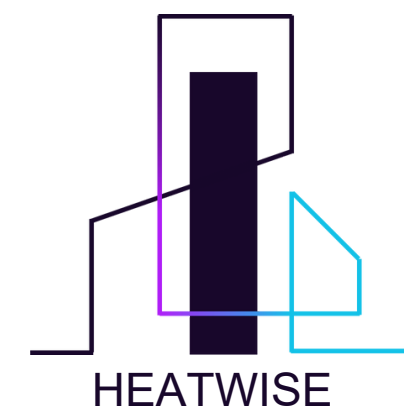
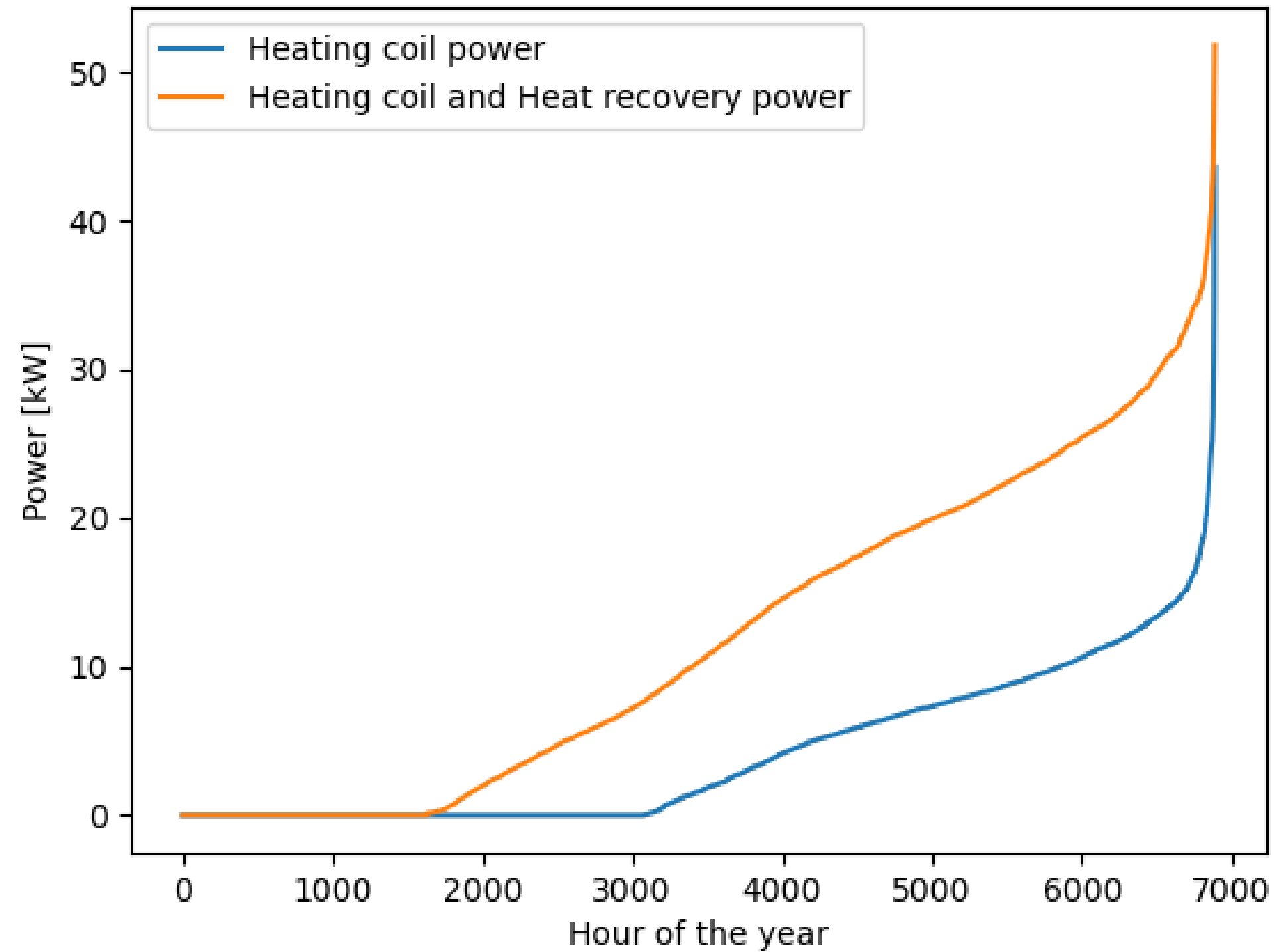

Hvordan kunne systemkoblingen se ud?

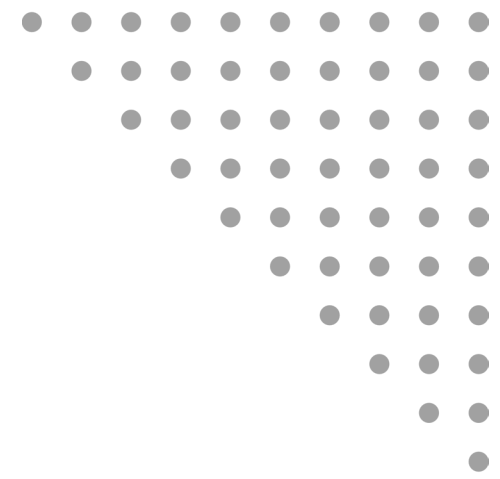

- Simplificeret eksempel på eksisterende varmt vands system på Thomas Manns Vej 23

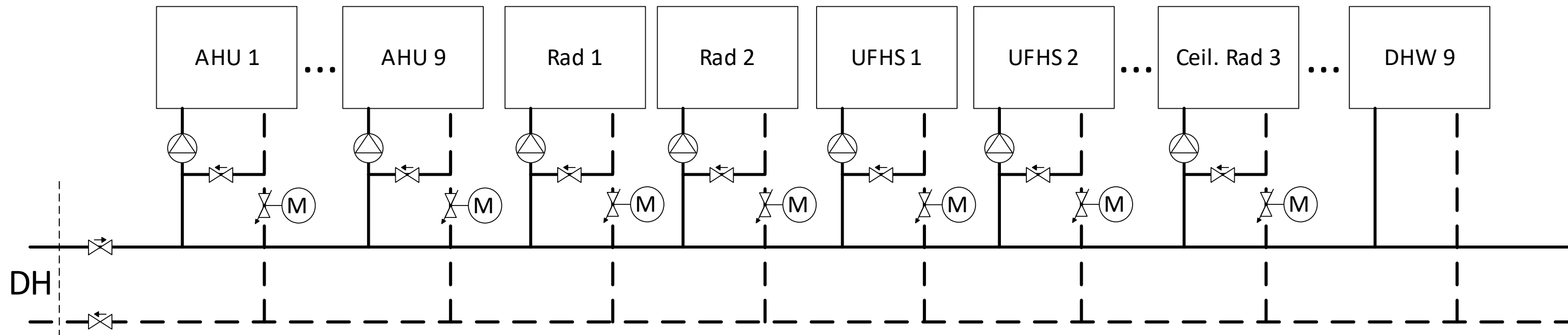

AHU = Ventilationsanlæg
Rad = Radiator system
UFHS = Gulvarme
Ceil. Rad = Strålevarme
DHW = Varmt brugsvand



Hvordan kunne systemkoblingen se ud?

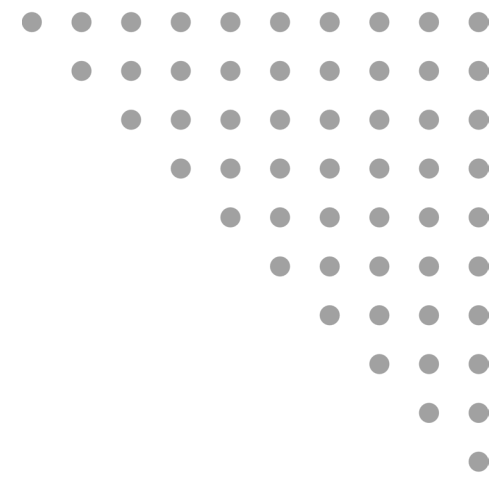

- Eksempel med kobling til hovedforsyningen

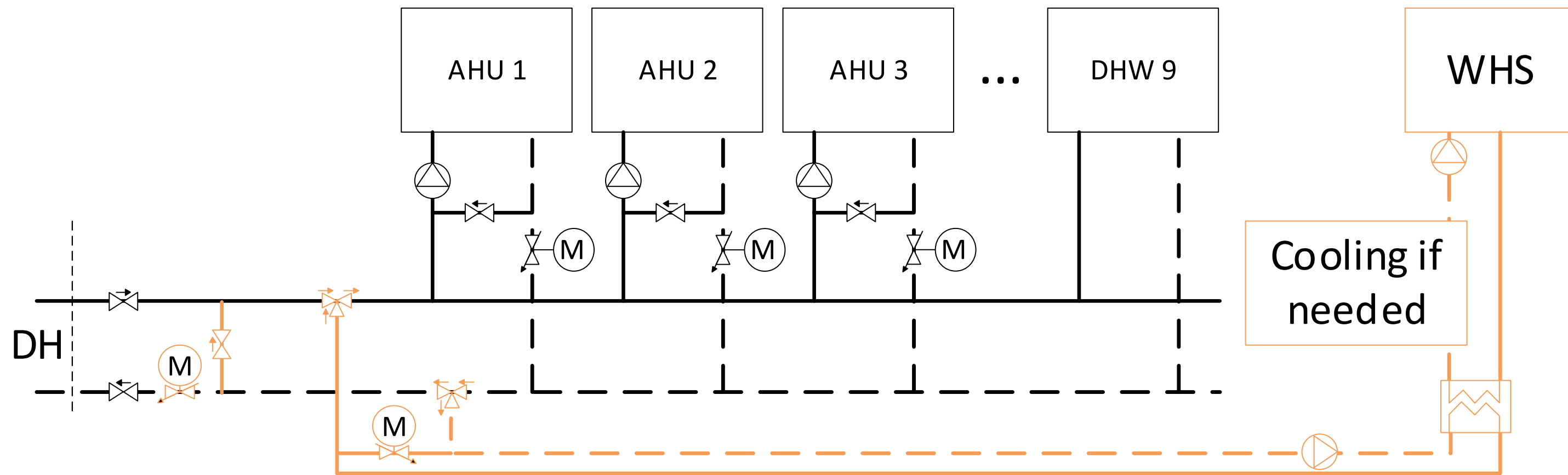

AHU = Ventilationsanlæg
Rad = Radiator system
UFHS = Gulvarme
Ceil. Rad = Strålevarme
DHW = Varmt brugsvand



Hvordan kunne systemkoblingen se ud?

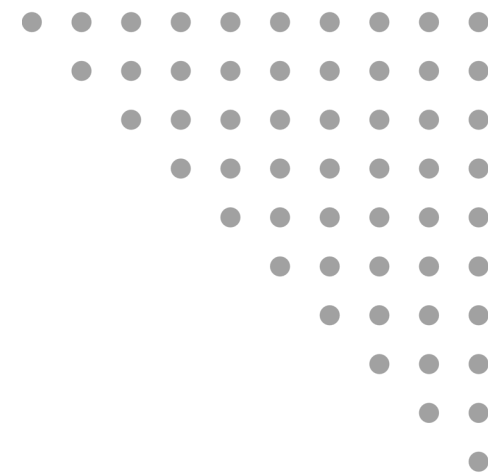

- Eksempel med kobling til individuelle systemer

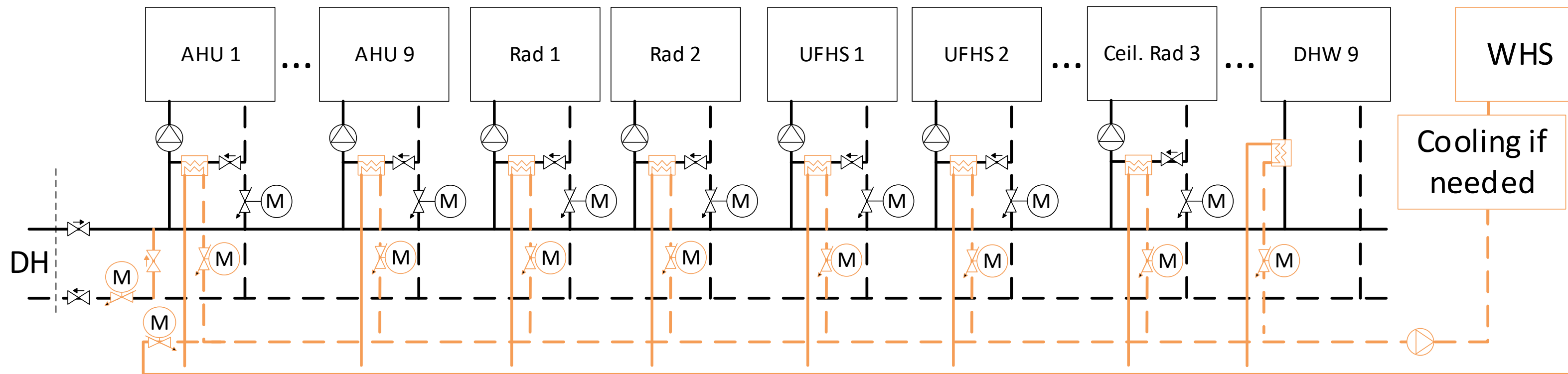

AHU = Ventilationsanlæg
Rad = Radiator system
UFHS = Gulvarme
Ceil. Rad = Strålevarme
DHW = Varmt brugsvand



Hvordan kunne systemkoblingen se ud?

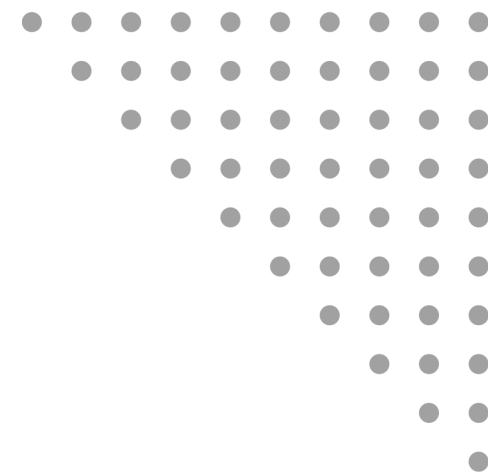

- Eksempel med kobling til grupper af systemer med lignende behov

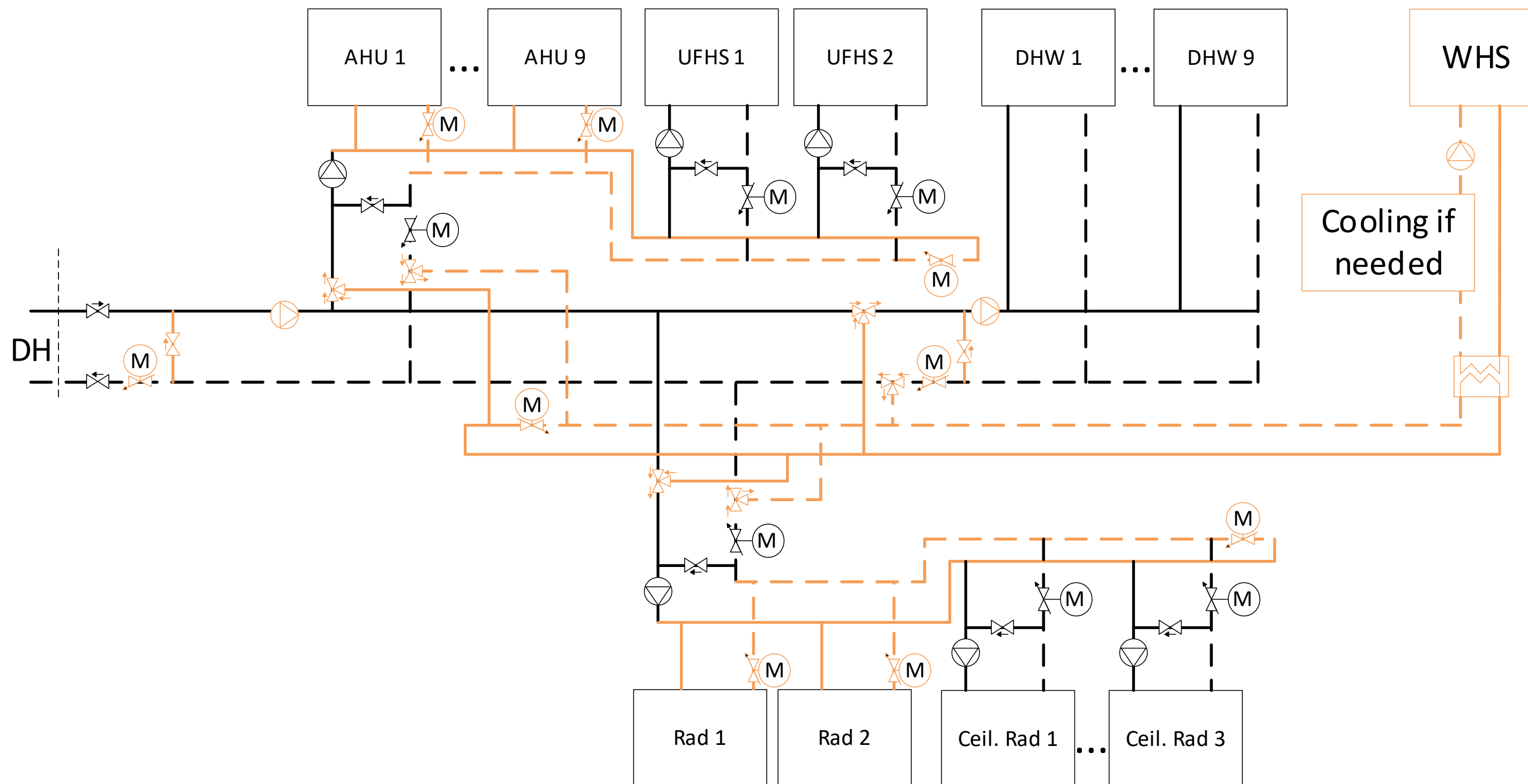

AHU = Ventilationsanlæg
Rad = Radiator system
UFHS = Gulvarme
Ceil. Rad = Strålevarme
DHW = Varmt brugsvand



Fremtidige perspektiver



- Når opvarmningen af bygninger bliver dækket af overskudsvarme, kan vi så bruge mere fri varme til at sikre et bedre indeklima?
- For server rum med væskekøling, kan bygningen blive fleksibel nok til at aftage al varme produceret så et køleanlæg kan spares væk eller mindskes?
- Kan overskudsvarmen bruges til fordampningskøling om sommeren?
 - Mange overskudsvarme kilder er "konstante" over året, så som server rum og supermarkeds kølemontre
- Bør genbrug af overskudsvarme indtænkes i den grønne omstilling på lige fod med vindmøller, solceller og lignende?



CONTACT

www.heatwise.eu



simonpm@build.aau.dk



+45 99407027



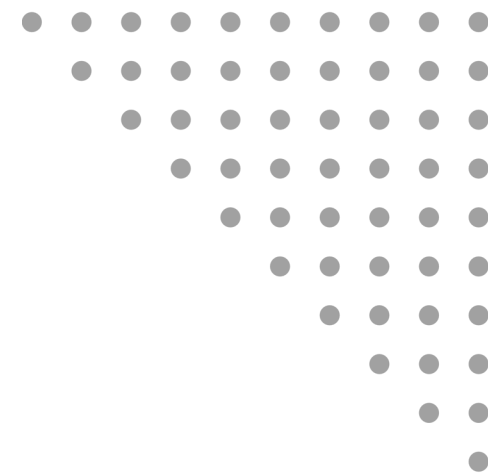

Hvordan nytænker du designet af varmesystemet og udnytter overskudsvarme i bygninger

Lokalgruppe Nordjylland



Program

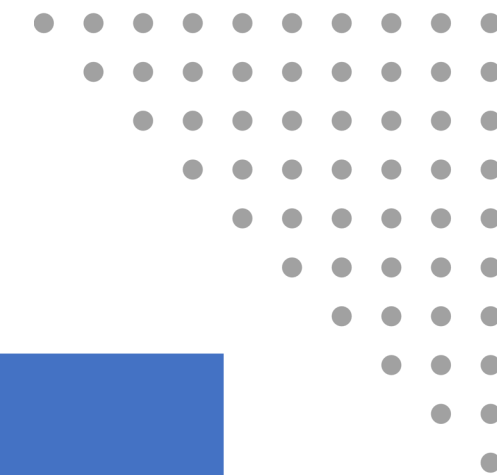

Tidspunkt	Titel	Olægsholder
14:00	Introduktion og præsentation af EU Horizon projektet "HEATWISE"	v/ Rasmus Lund Jensen, Aalborg Universitet
14:15	Anvendelse af lokal overskudsvarme i bygningssystemer. Måling, potentiale, og design.	v/ Simon Pommerencke Melgaard, Aalborg Universitet
14:30	Fordampningskøling i praksis. Hvad kan det bruges til og hvordan gøres det (Lærdom og udfordringer)	v/ Jess Rowedder, SolarCooling
14:50	Kaffepause	
15:10	Nuværende regler omkring genbrug af overskudsvarme lokalt	v/ Klaus Lunddal Brose, Dansk Fjernvarme
15:50	Rundbord med Rasmus Lund Jensen, Jess Rowedder, og Klaus Lunddal Brose, hvor der er mulighed for at stille spørgsmål og diskutere potentiale udfordringer og muligheder	
16:20-16:30	Rundvisning i mindre serverrum, hvor der er lavet forskellige eksperimenter for at forbedre effektiviteten af luftkølingen	v/ Simon Pommerencke Melgaard, Aalborg Universitet

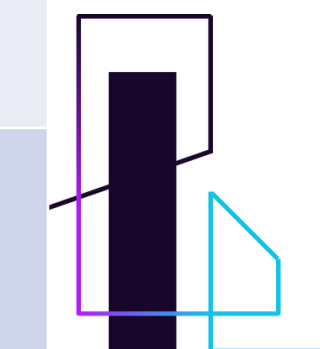

Overskudsvarme i EU



- Estimeret overskudsvarme i EU 2.860 TWh/y
- EU's forbrug af energi til varme og varmt brugsvand 3.180 TWh/y
 - (>50% af EU's samlede energiforbrug)
- For at kunne dække en fjerdedel af EU's behov skal vi kunne genbruge 28% af overskudsvarmen



Øverskudsvarme i EU

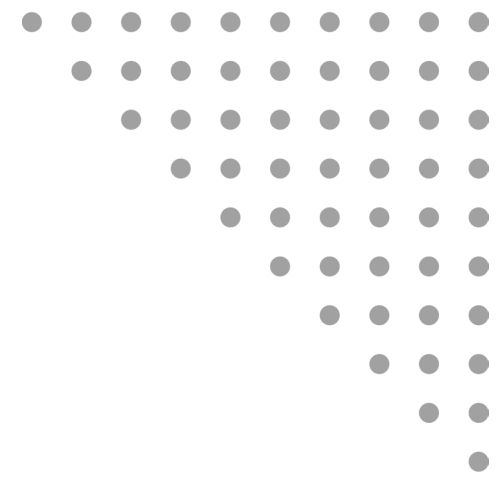

- Ikke alt øverskudsvarme kan genbruges
 - For lav temperatur
 - For langt til aftagere
 - For dyrt – vores bygninger er ikke forberedt til det
- Fremover skal vores nybygninger være forberedt på og kunne producere vedvarende energi
- Burde de ikke også være forberedt på at kunne udnytte øverskudsvarme?



Overskudsvarme i EU

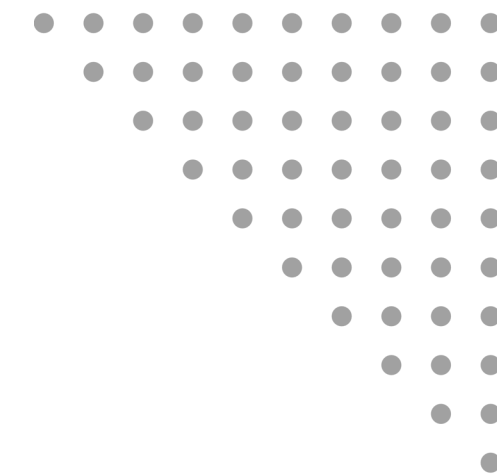

- Meget af overskudsvarmen skal via fjernvarmenettene (kræver relativt høje temperaturer)
 - I Danmark ofte mellem 60 og 80 grader
 - I mange andre lande +90 grader
- Mest muligt bør bruges direkte i bygningen eller nabobygninger (kan udnytte lavere temperaturer end fjernvarme)





Funded by
the European Union



Schweizerische Eidgenossenschaft
Confédération suisse
Confederazione Svizzera
Confederaziun svizra

Swiss Confederation

Federal Department of Economic Affairs,
Education and Research EAER
**State Secretariat for Education,
Research and Innovation SERI**
EU Framework Programmes

H O R I Z O N E U R O P E

H E A T W I S E

www.heatwise.eu

Aalborg Maj 2026



Raise of edge computing



Deploy **≥ 10,000 edge nodes**
in the EU for fast data access
and processing



Possible scenarios for the development of the energy demand of data centres in the EU27 until 2030 (Source: Borderstep Institute)

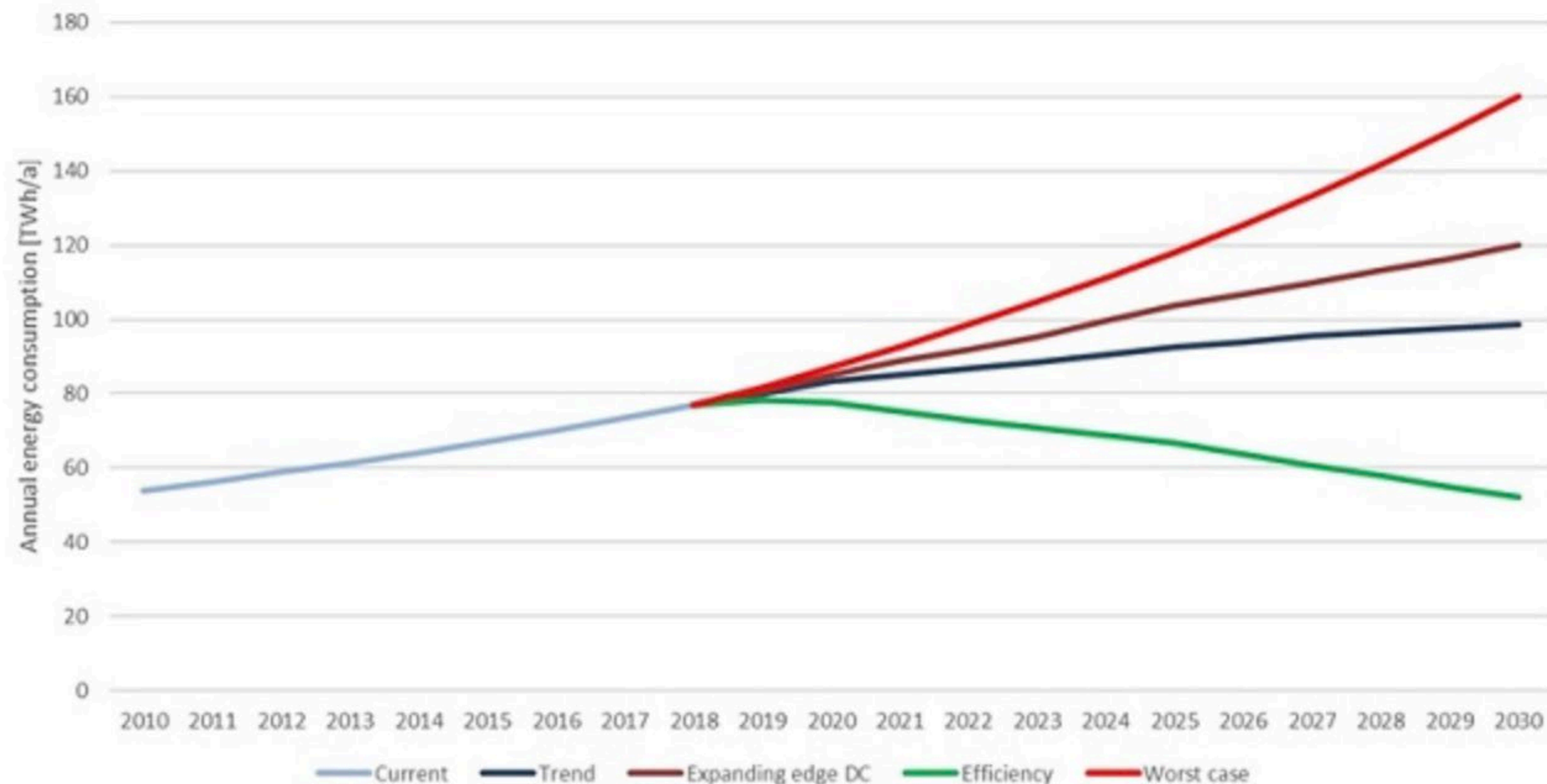

In 2018 the energy consumption of data centres in the EU was 76.8 TWh. This is expected to rise to 98,52 TWh by 2030, a 28% increase.



Two-Phase DLC cooling loop

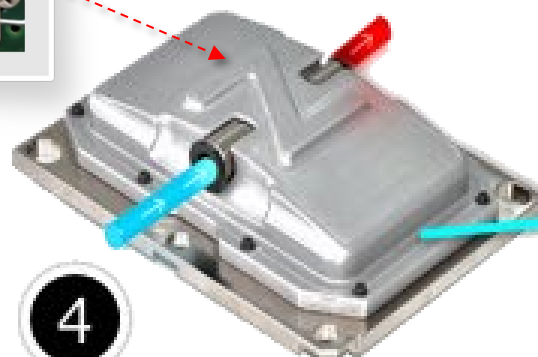
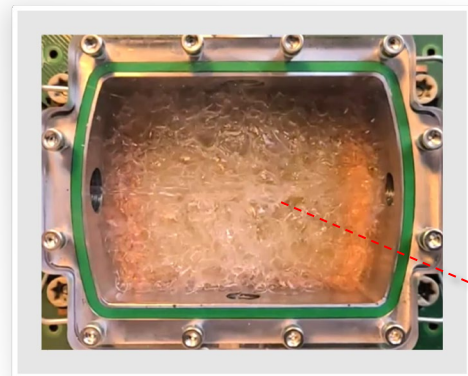

4

Inside the ZutaCore Dielectric Cold Plate:

1. Receive dielectric liquid based on CPU cooling demand
2. CPU heat boils the dielectric liquid
3. Liquid evaporates and cools the CPU

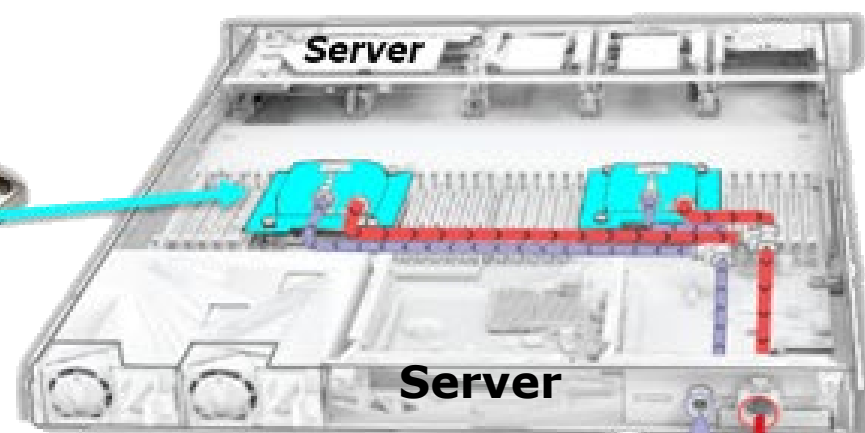

3

Liquid Chamber

Vapor/Gas Chamber

5

Evaporated gas/vapor transported to manifold
Single tube delivers dielectric liquid in parallel to cold plates in a server.

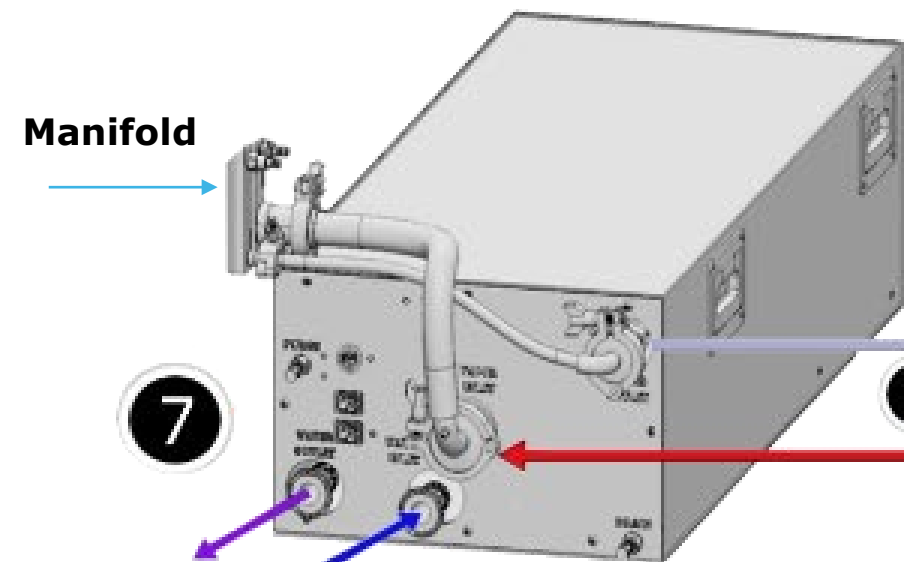

Manifold

7

1 Pump inside HRU delivers Dielectric liquid to manifold

2 Manifold Distributes dielectric liquid to all servers in the rack

2

Evaporated gas/vapor transported to HRU

6

(b) HRU rejects heat into facilities water (outlet)

(a) Facility water delivered to HRU (inlet)

Dielectric Cold Plate

Manifold

HRU-W

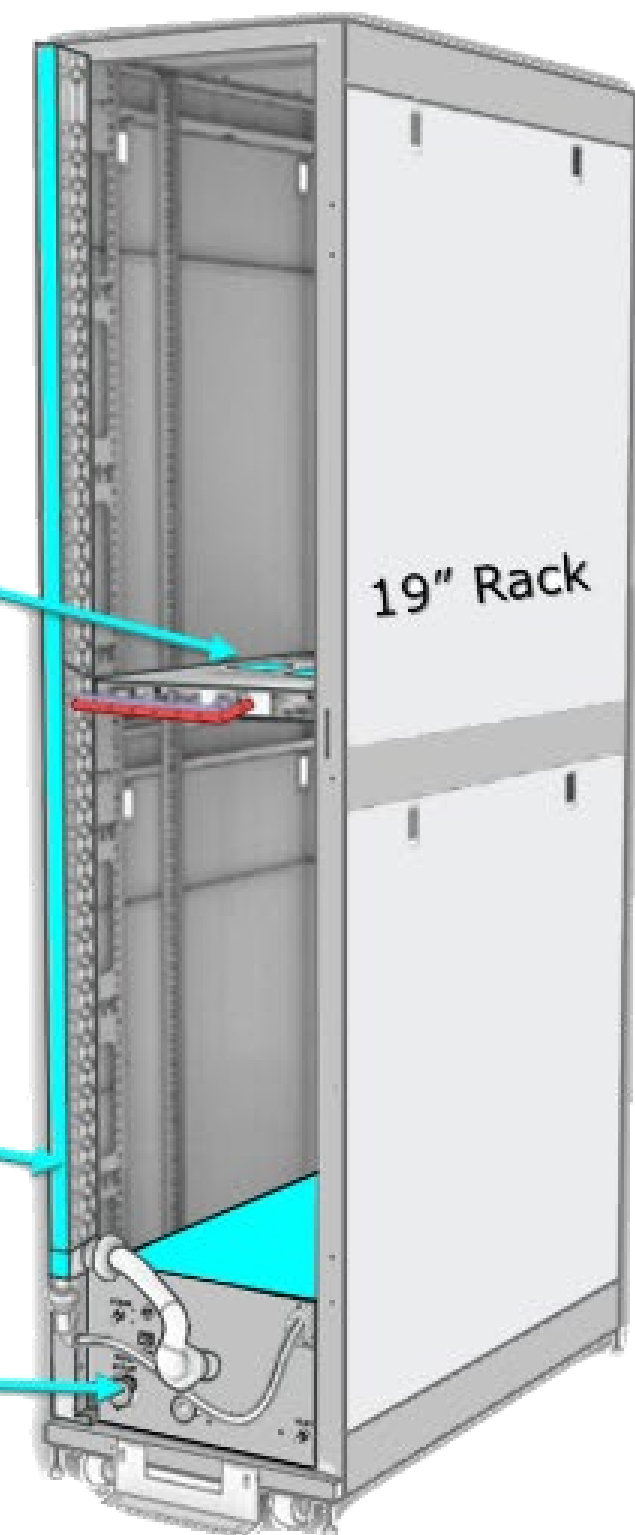

19" Rack

MANIFOLD

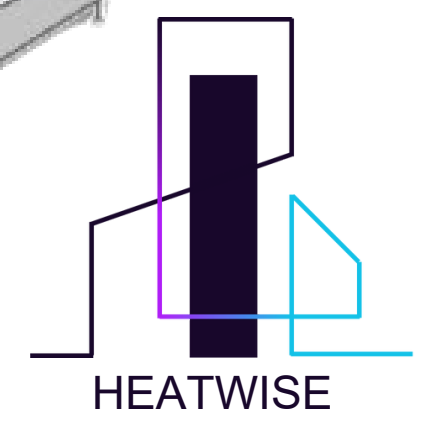

HEATWISE



Waste heat potential of buildings

Rasmus Lund Jensen & Simon Melgaard
Aalborg University (AAU), Denmark





No two buildings are alike

Buildings have:

- Very different energy need
- Very different insulation level
- Very different HVAC systems
- Very different use profile
- Designed for very different heating supply system





AAU pilot building 2016

- University building with laboratories, offices for staff, lecture rooms, student group rooms
- Houses roughly 150 employees and 600 students
- Total area of approximately 9.000 m²
- HVAC systems
 - 9 ventilation units with heat recovery
 - 5 heating systems
 - DHW production by heat exchangers
 - 3 cooling units
 - Schneider BMS system





Empa pilot

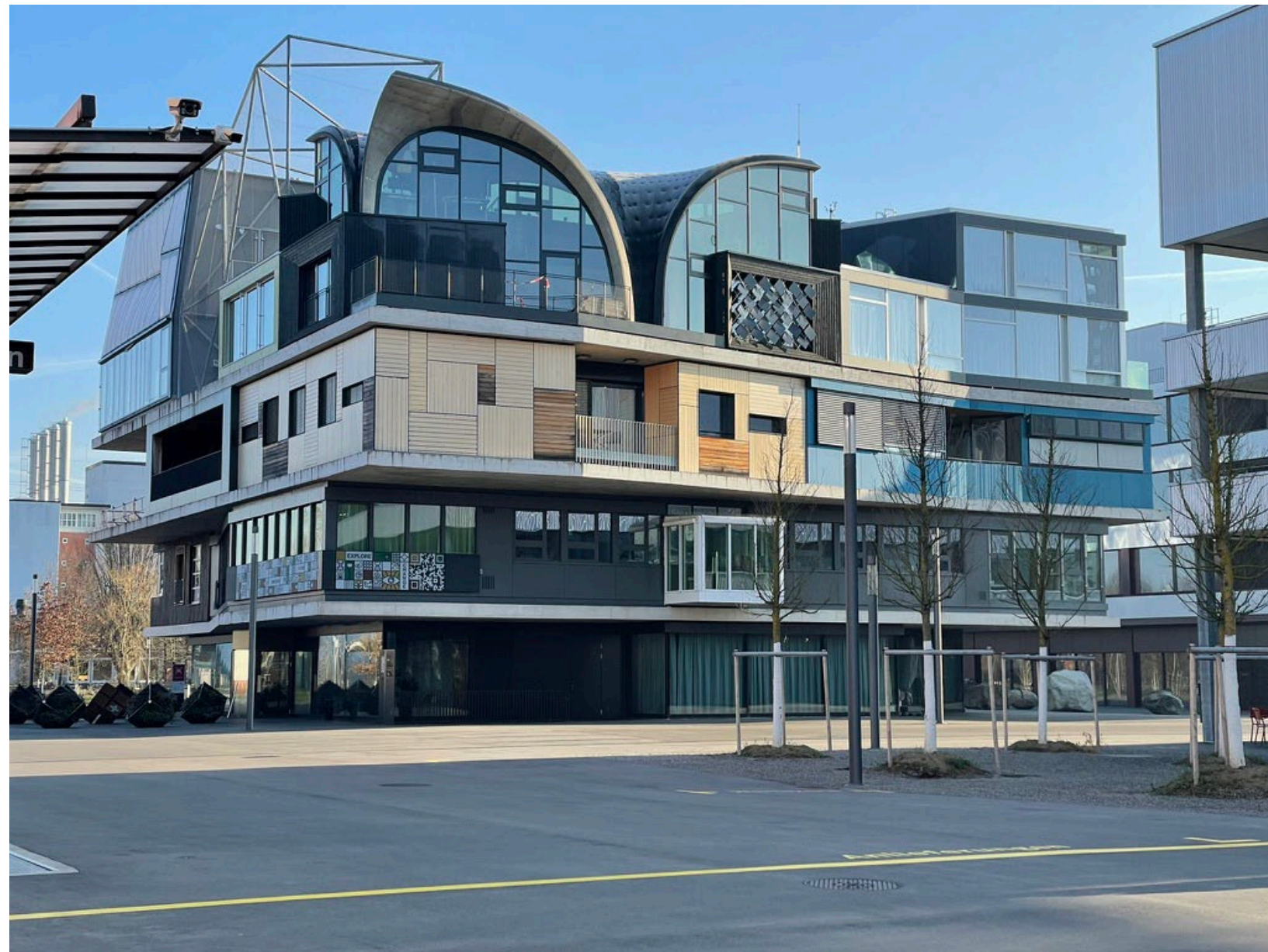



Temperature need for Empa pilot

Sprint

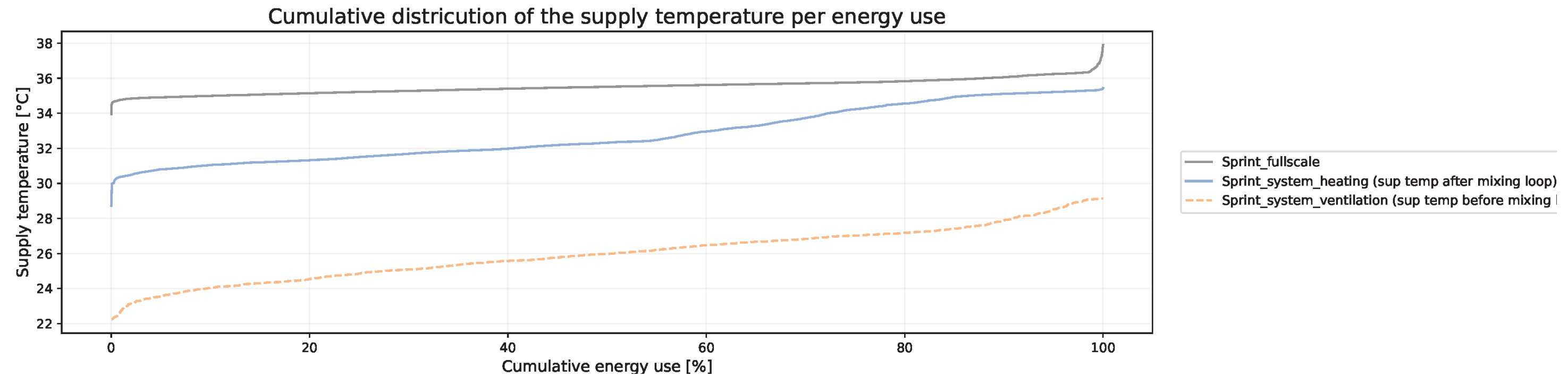

HILO

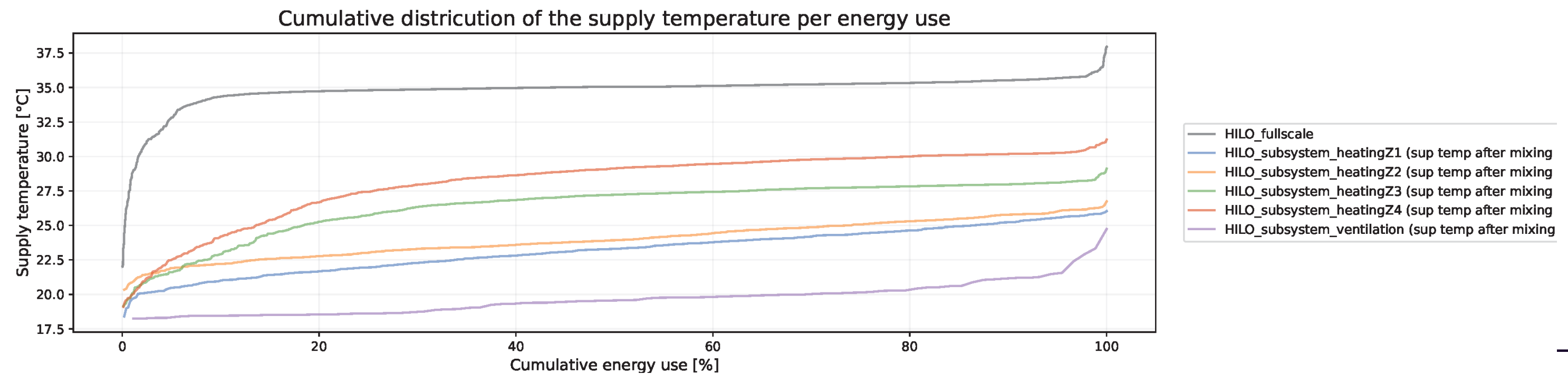



Energy use per year (kWh/m² year)

- More than 80% of the heat can be substituted by waste heat from datacentres
- The high temperatures for ventilation are due to a malfunctioning mixing valve and measuring before the mixing loop

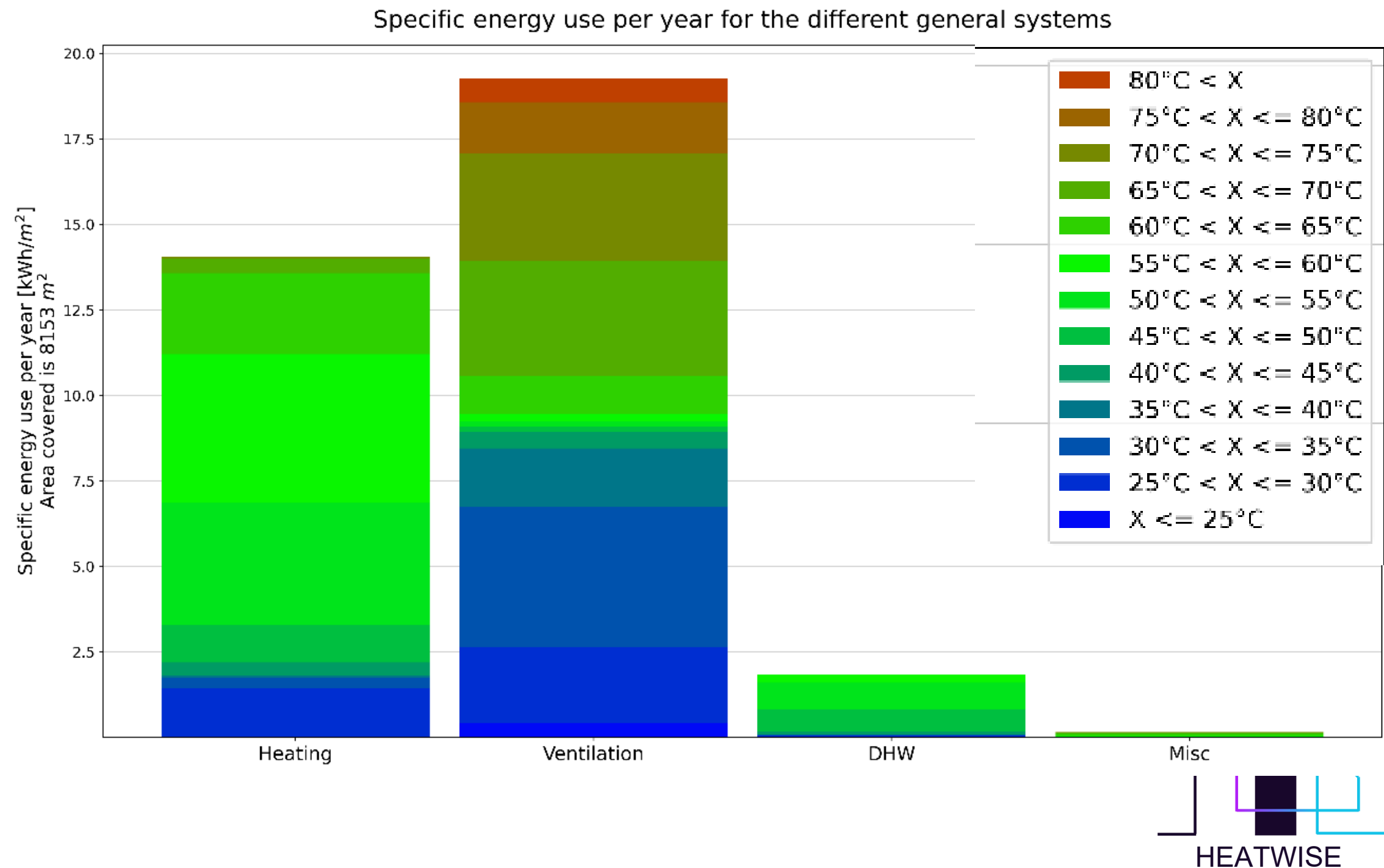



Conclusions

- Huge potential to use waste heat from datacenters – especially if connected to the individual HVAC systems
- If you want to evaluate the potential of a building, you need to measure at the individual systems, e.g. after the mixing loops
- The building can act as a heat sink even when there is no need for heating in order to reduce the cooling system for the datacentre

